

**SURFACE KEY**

MAGENTA	visible (general) surface
RED	70-120µm (main surface)
GREEN	40-120µm (secondary surface)
CYAN	0-120µm (tertiary surface)
BLUE	only powdermist allowed
ORANGE	free of coating
VIOLETT	high gloss
WITHOUT COLOUR	raw

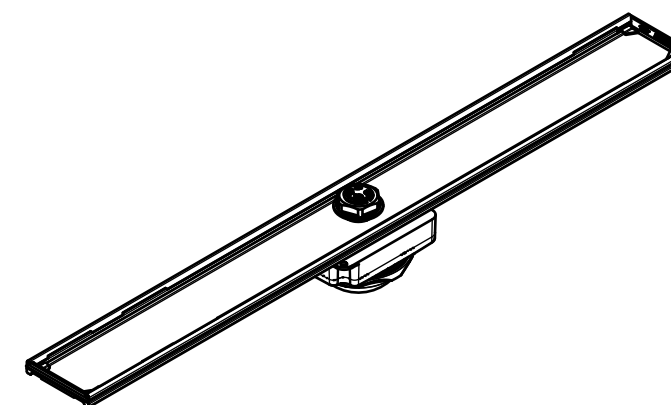
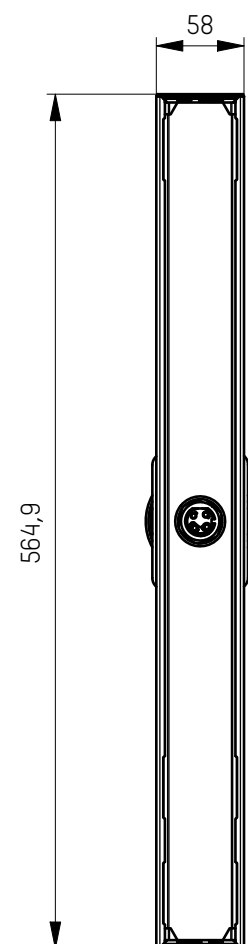
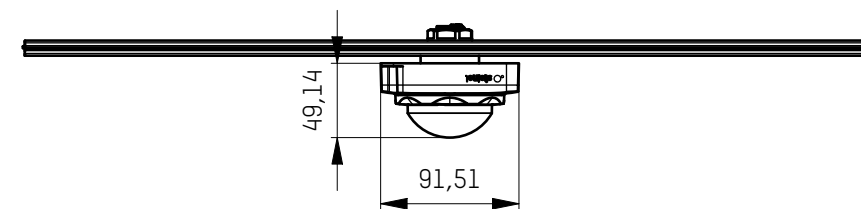
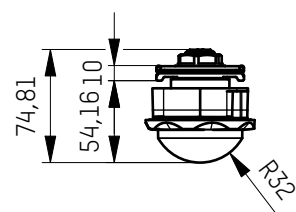

00	first release	11.05.2023	Ansola
rev.	description	checked date	checked by
REVISIONS-HISTORY			

technical information / manufacturing note		general manufacturing tolerances N/A	drawn by Ansola	<b>MOLTO LUCE®</b>
		material ACC. TECHN. INFO	creation date 11.05.2023	
		weight 0,000 kg	description SIMPLE	drawing number ENG000029114
		surface finish N/A	article number 610-0295xxxxxxxxxx	
		surface according ISO 1302	undimensioned edges according DIN ISO 13715	
		threads must be free of coating		
all dimensions and tolerances related uncoated surfaces		max. thickness of coating: 120µm	scale 1 : 5	sheet 1 of 1 A3

The unauthorized and / or against the rules use of these documents and possible attachment are not permitted and are judicially pursued